

Sustainable Water Futures Begin with Governance:

**Why Good
Water Science
still needs
Good
Governance**

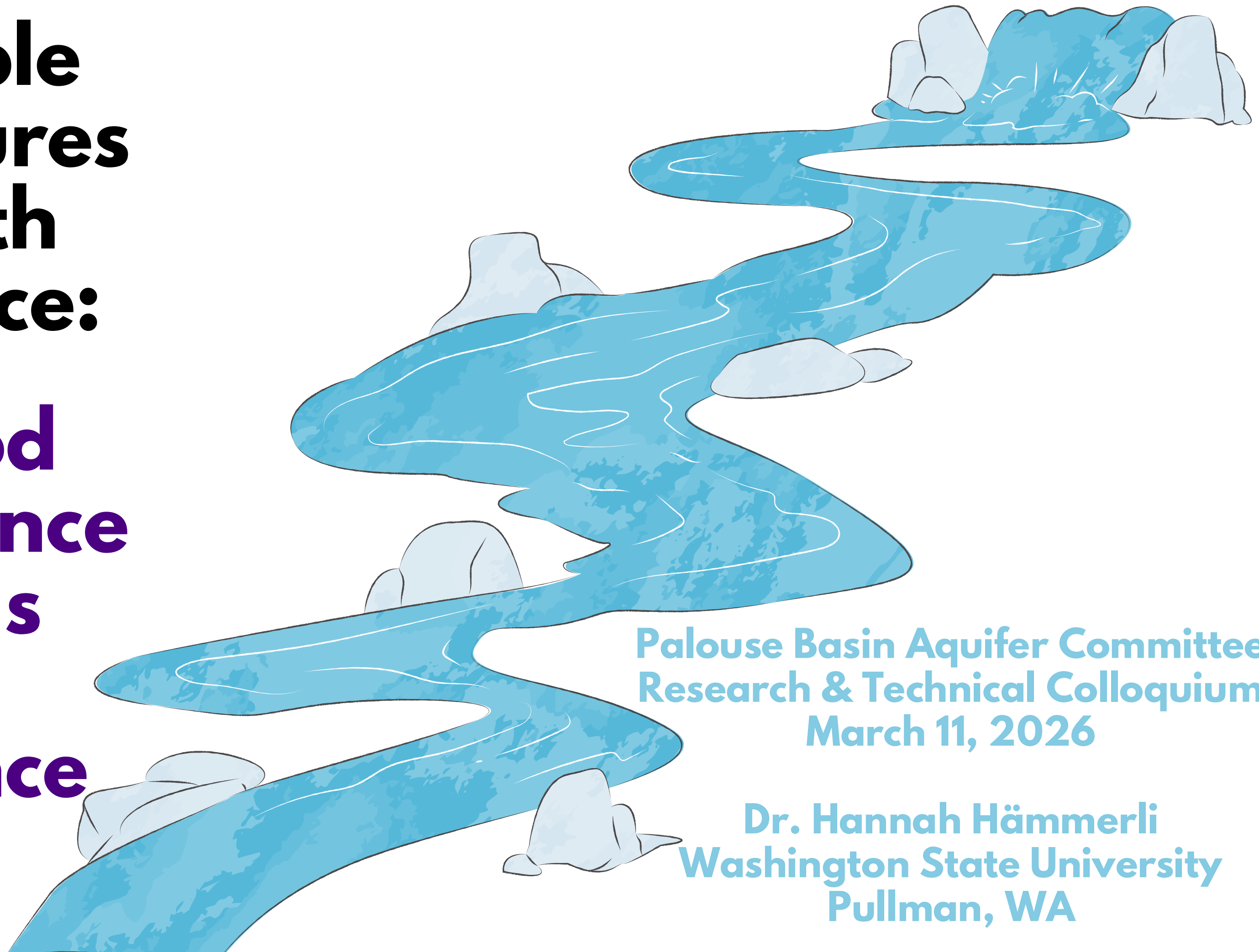

**Palouse Basin Aquifer Committee
Research & Technical Colloquium
March 11, 2026**

**Dr. Hannah Hämmerli
Washington State University
Pullman, WA**

OVERVIEW

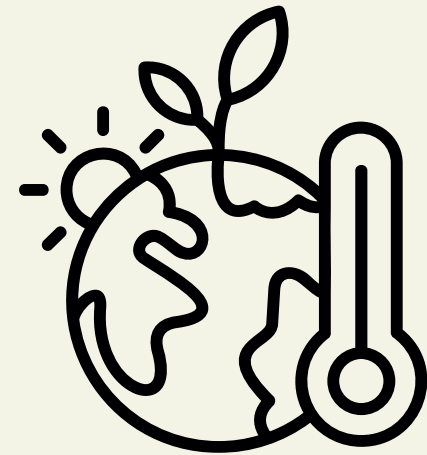

SET THE SCENE: ROLE
OF SOCIAL
SCIENCES



FOOD FOR THOUGHT:
WATER GOVERNANCE
& COLLABORATION

GLOBAL AVERAGE TEMPERATURE

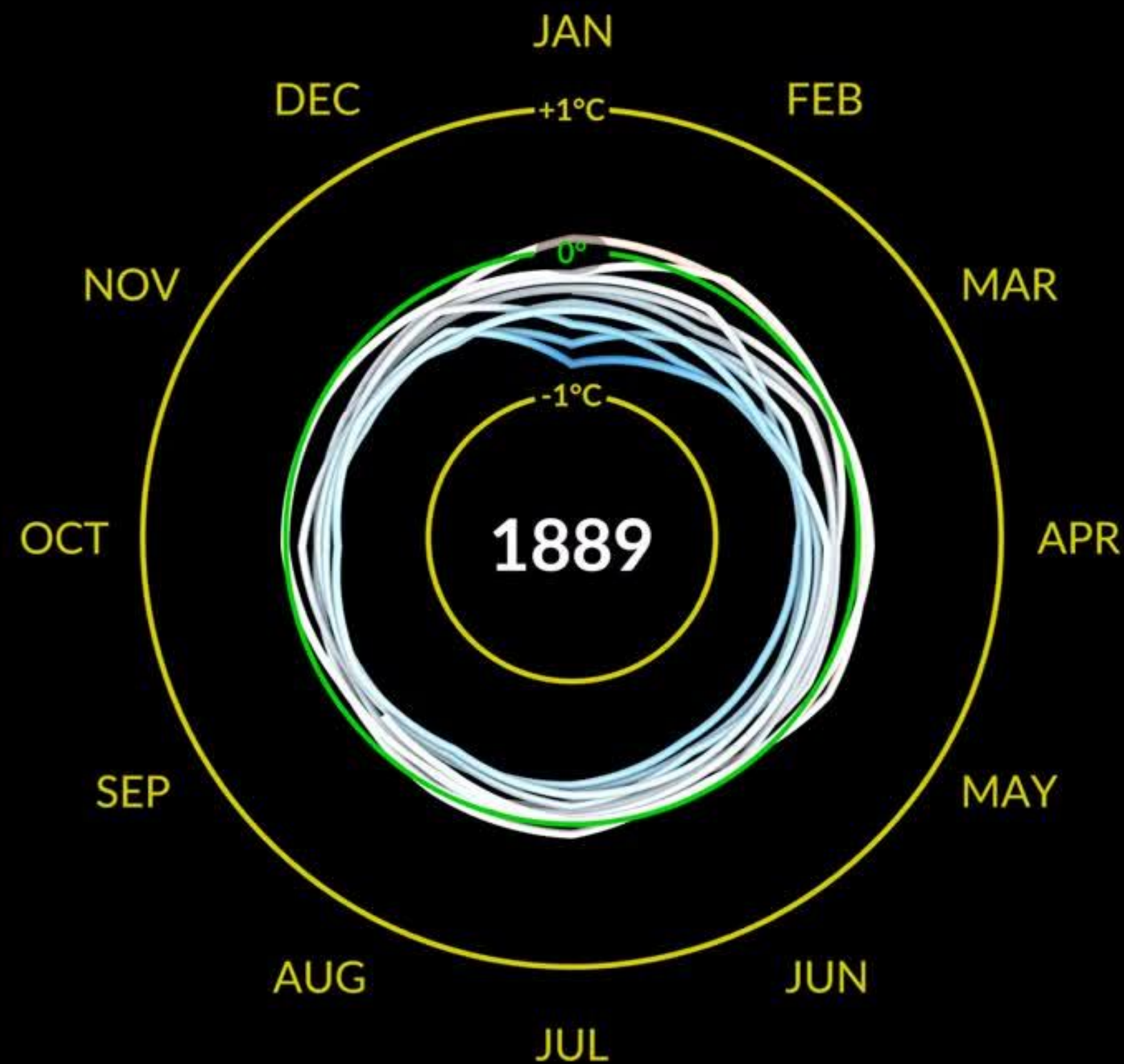

UNCERTAINTIES, COMPLEXITIES, & CHANGES

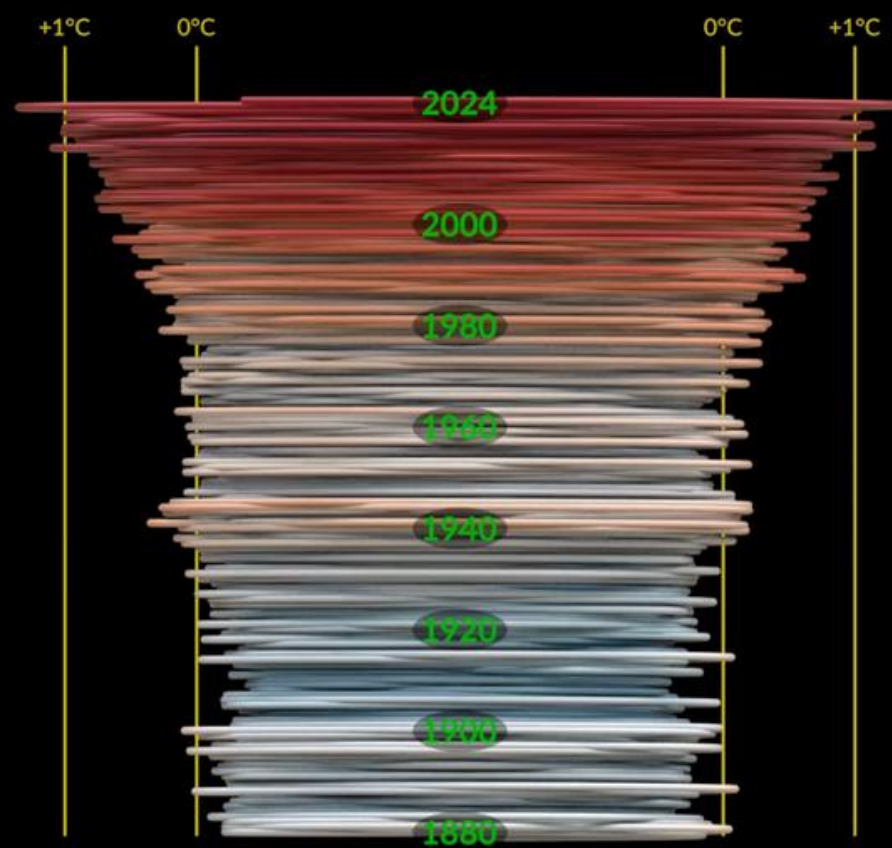

climate change

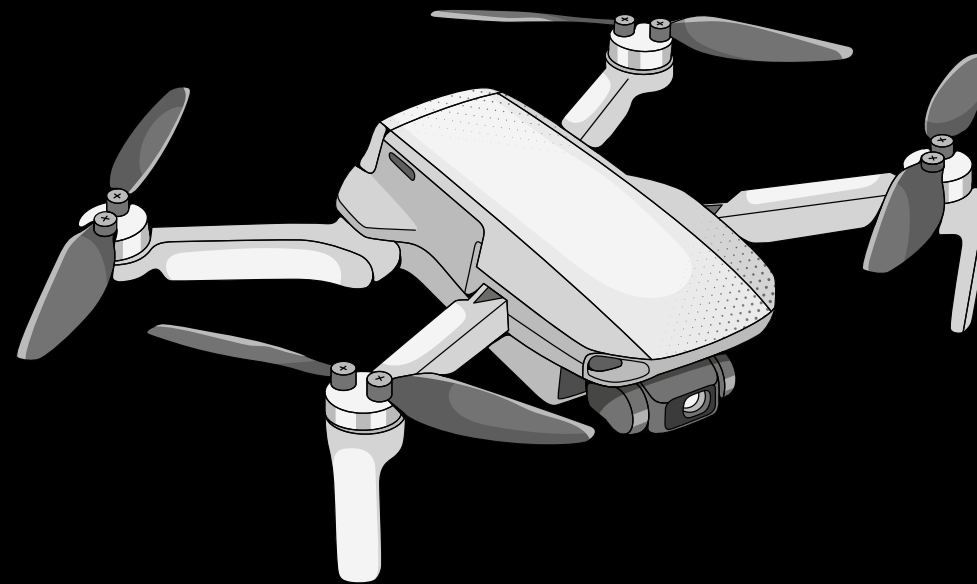

technologic change



political change

Water Crisis



Acute, time-limited episode

- Shock-driven disruption (e.g., droughts, floods, contamination) that temporarily pushes the system beyond capacity with no or little irreversible damage
- Emergency measures, short-term restrictions, and crisis communication aimed at mitigation and rapid restoration

Water Crisis



Acute, time-limited episode

- Shock-driven disruption (e.g., droughts, floods, contamination) that temporarily pushes the system beyond capacity with no or little irreversible damage
- Emergency measures, short-term restrictions, and crisis communication aimed at mitigation and rapid restoration

Water Bankruptcy



Persistent post-crisis state

- Long-term over-extraction has degraded aquifers, rivers, and ecosystems, reduced hydrological carrying capacity, and caused irreversible damage
- Only partial, costly recovery is possible; governance must focus on demand reduction, reallocation, and adaptation

SCIENCE FOR INNOVATIVE SOLUTIONS

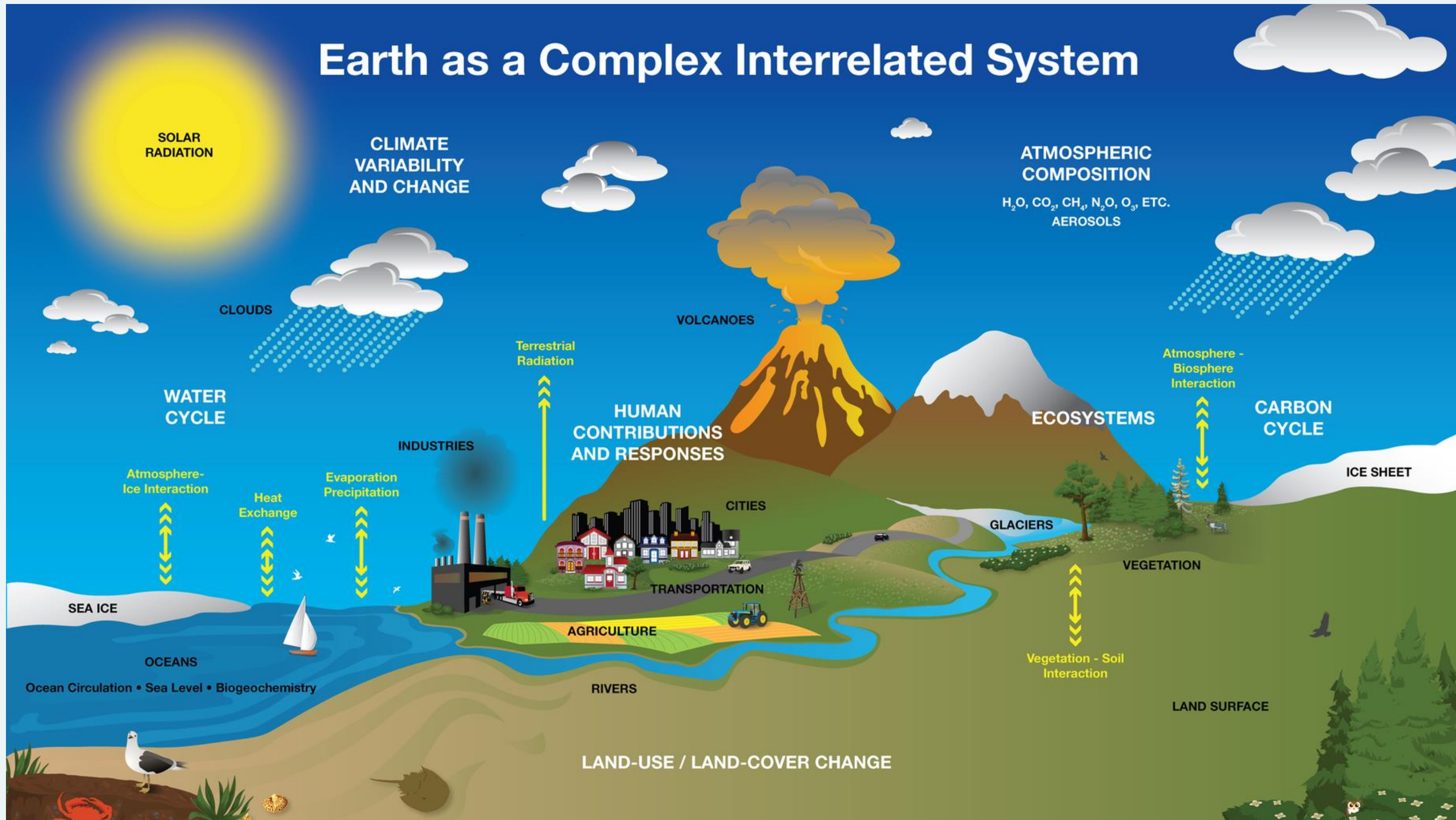

Climate science requires STEM

- understanding the physical climate system
- understanding its components

SCIENCE FOR INNOVATIVE SOLUTIONS

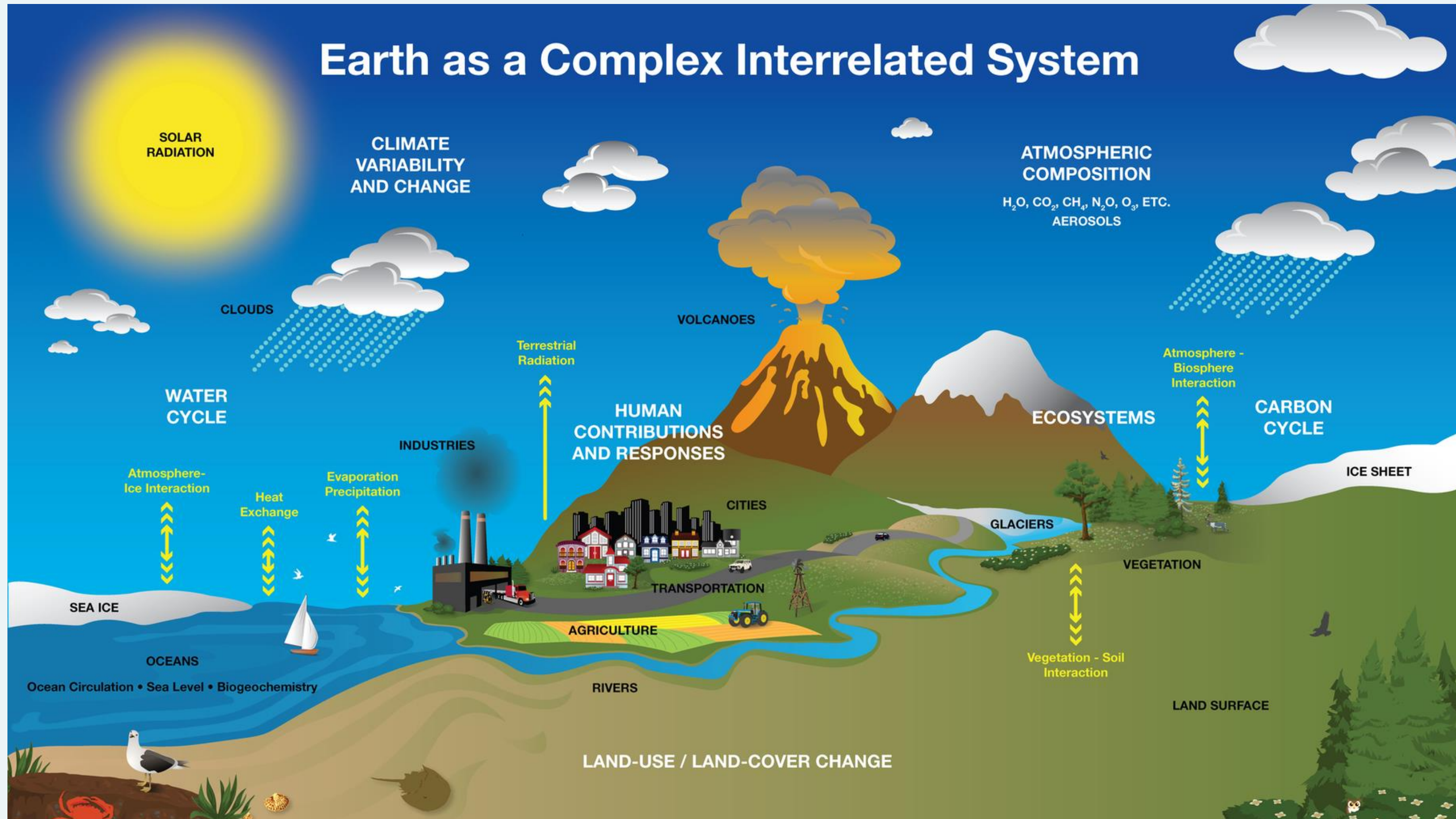

Climate science requires STEM

- understanding the physical climate system
- understanding its components

SOLUTIONS require **STEMS**

- **social science:** “society”, governance, institutions, etc. are an integral component of the climate (& water) system

USGS
 Water Data For The Nation Blog
 About Categories Keywords Tags

A New Take on the Water Cycle

On October 13th 2022, we released a new water cycle diagram! This update re-envision the water cycle, placing human activities at the forefront. We designed it to emphasize scientific accuracy, information design, and usability in educational settings. We hope that students of all ages better understand how humans affect where water is on Earth and how it moves, so that we can work towards using water more sustainably.

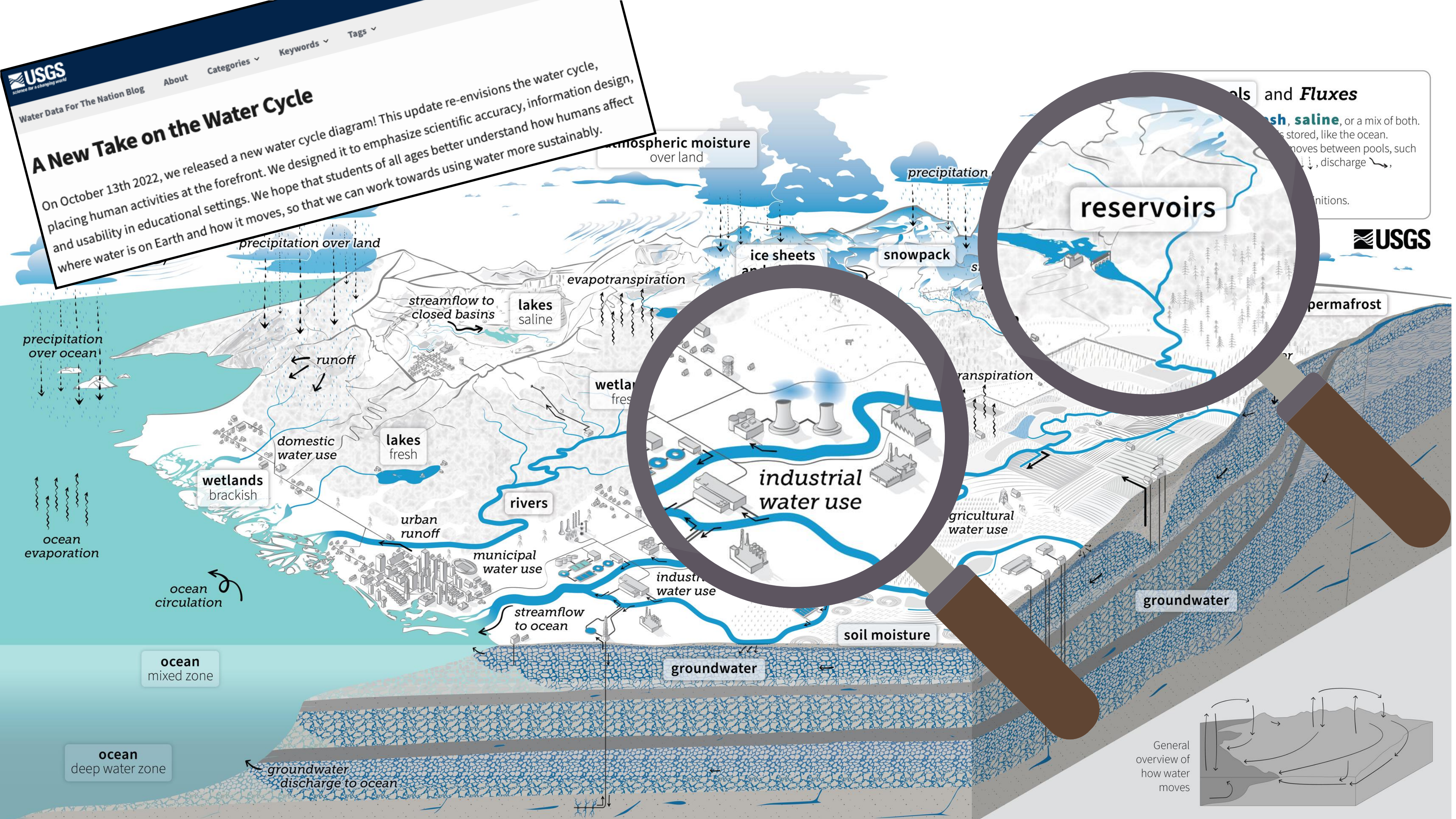

Salts and Fluxes
 fresh, saline, or a mix of both.
 is stored, like the ocean.
 moves between pools, such as
 discharge

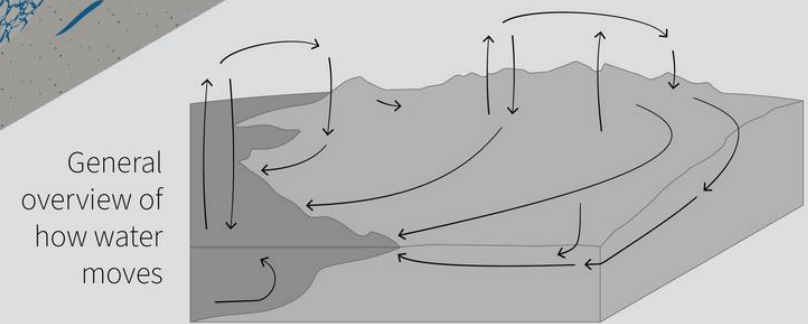

Hydrosocial Cycle

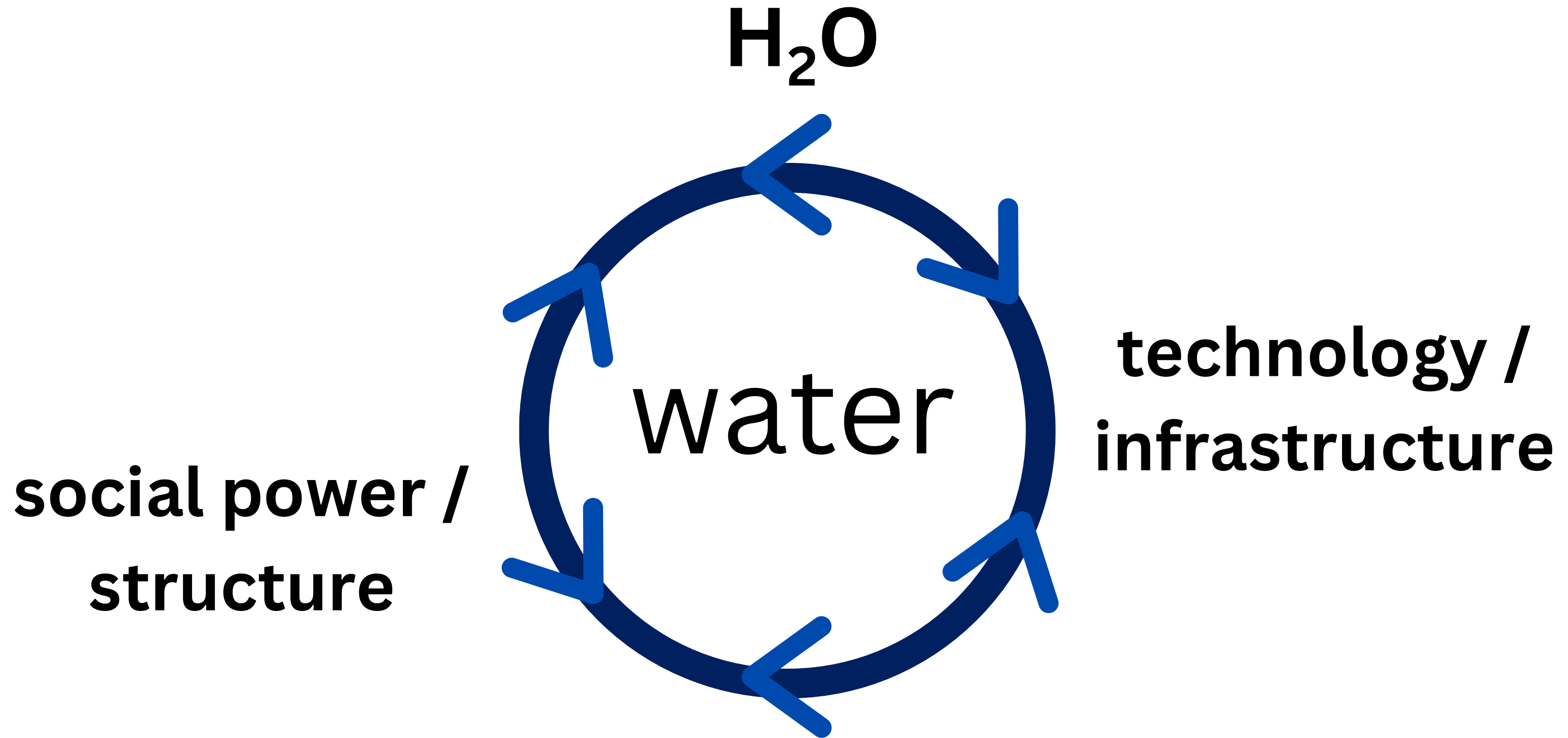

after Linton & Budds (2014)

See also Swyngedouw (2006), Bakker (2003)

Key ideas



(1) Water challenges are governance challenges

(2) Blue Peace

(3) Actionable Insights

Water challenges are governance challenges

“Water governance has emerged as one of the **most critical areas** in the context of sustainable water resources development and services, **necessary to respond to global water shortages** – a crisis which is not about having too little water to satisfy our needs, but rather **a crisis of managing water and making it accessible to all.**”

-UNDP, 2015

social-ecological
system

Water

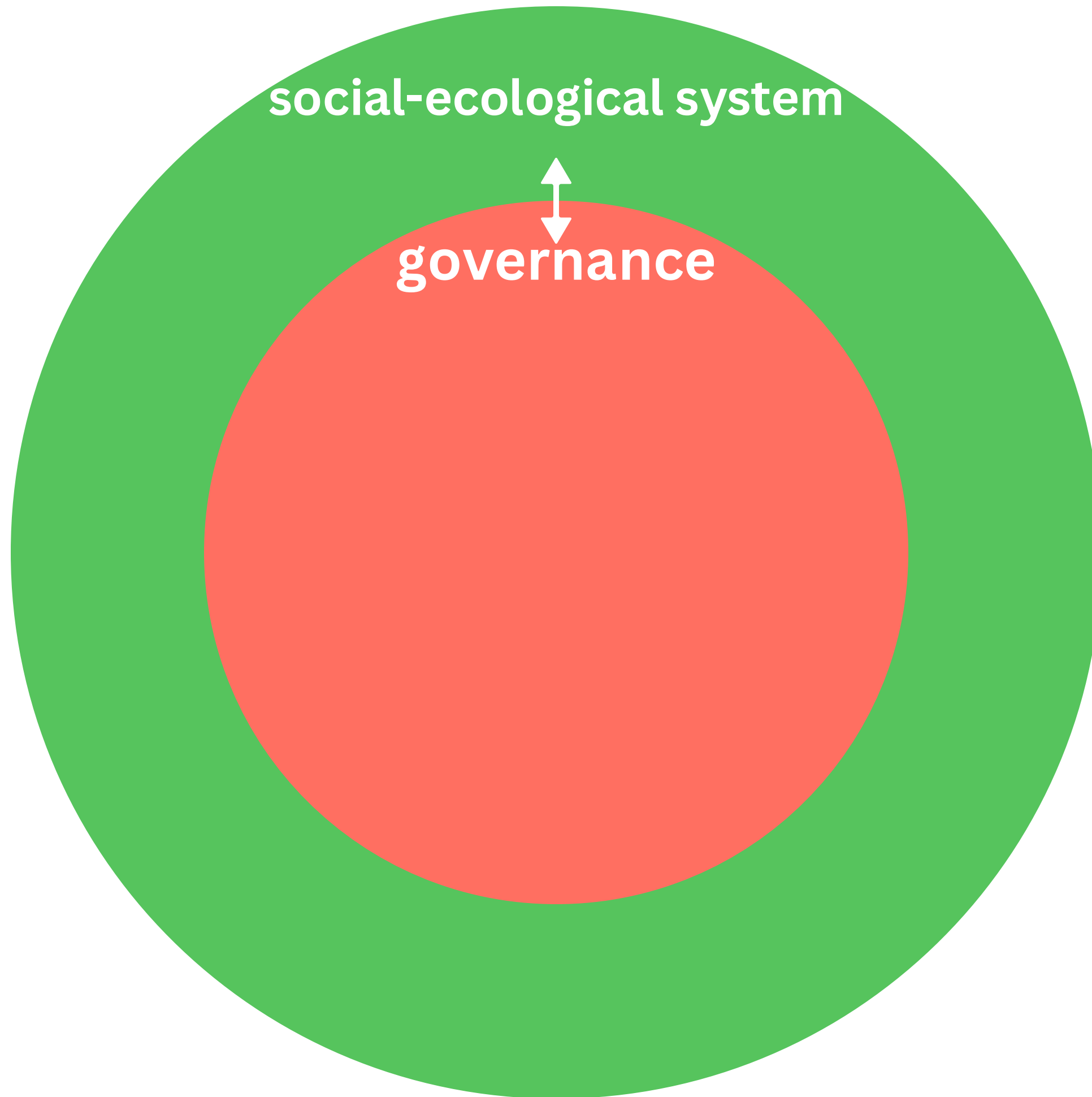

WATER GOVERNANCE:
THE SYSTEMS, PROCESSES, AND/OR
PRACTICES THAT SHAPE HOW
SOCIETIES MAKE DECISIONS ABOUT
WATER

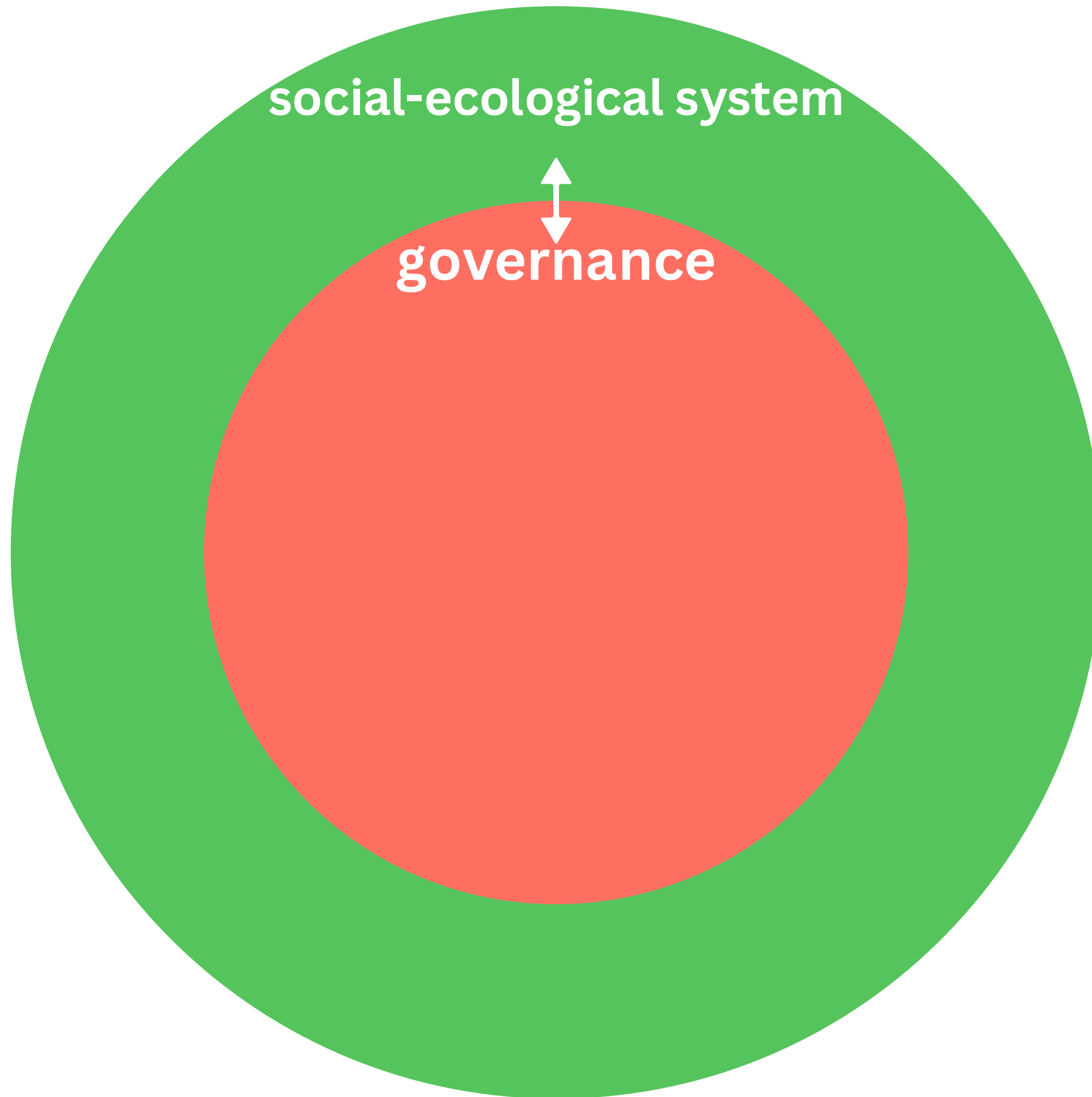

A FEW DISTINCTIONS

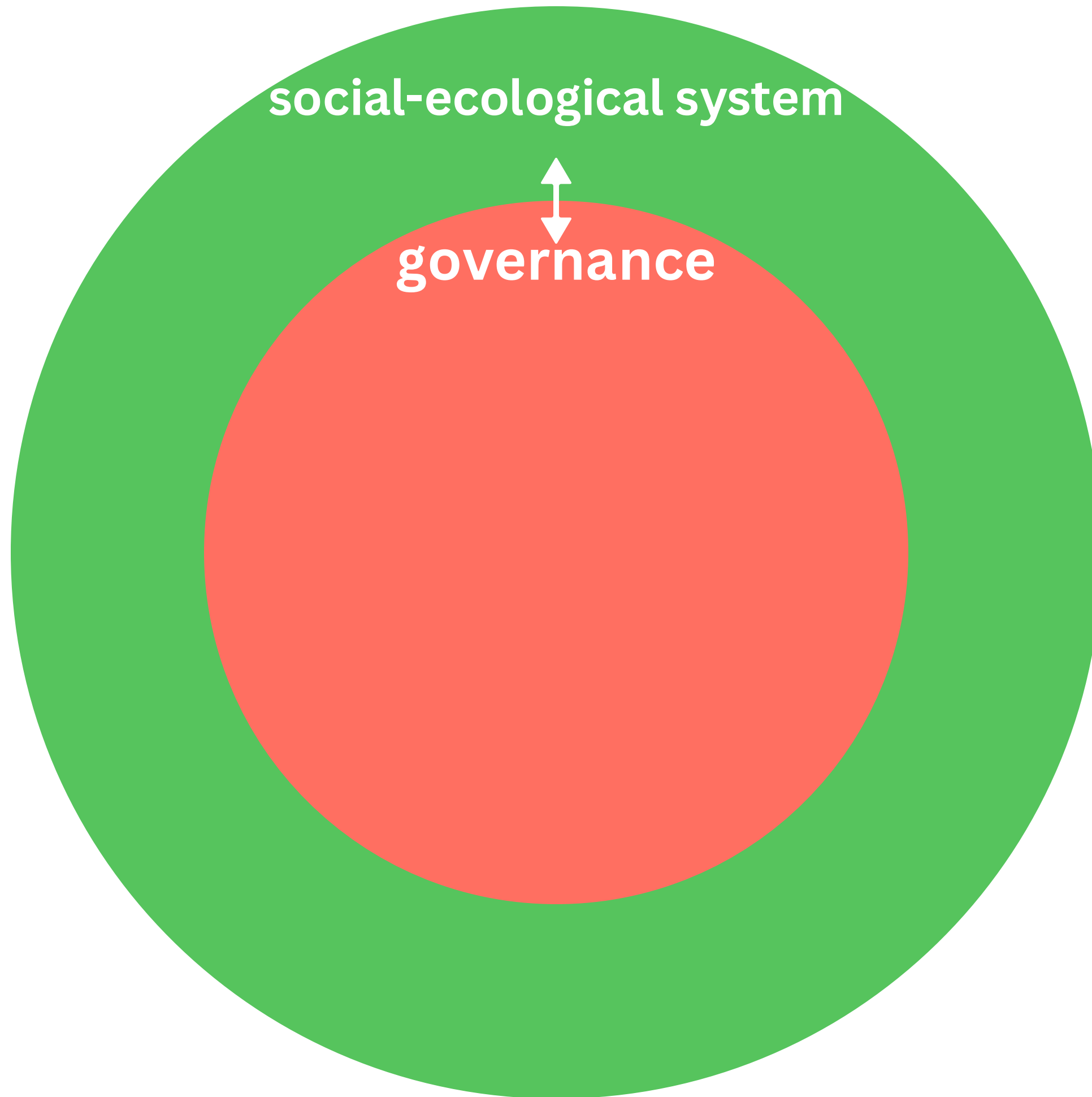

A FEW DISTINCTIONS

- Difference between
government and governance

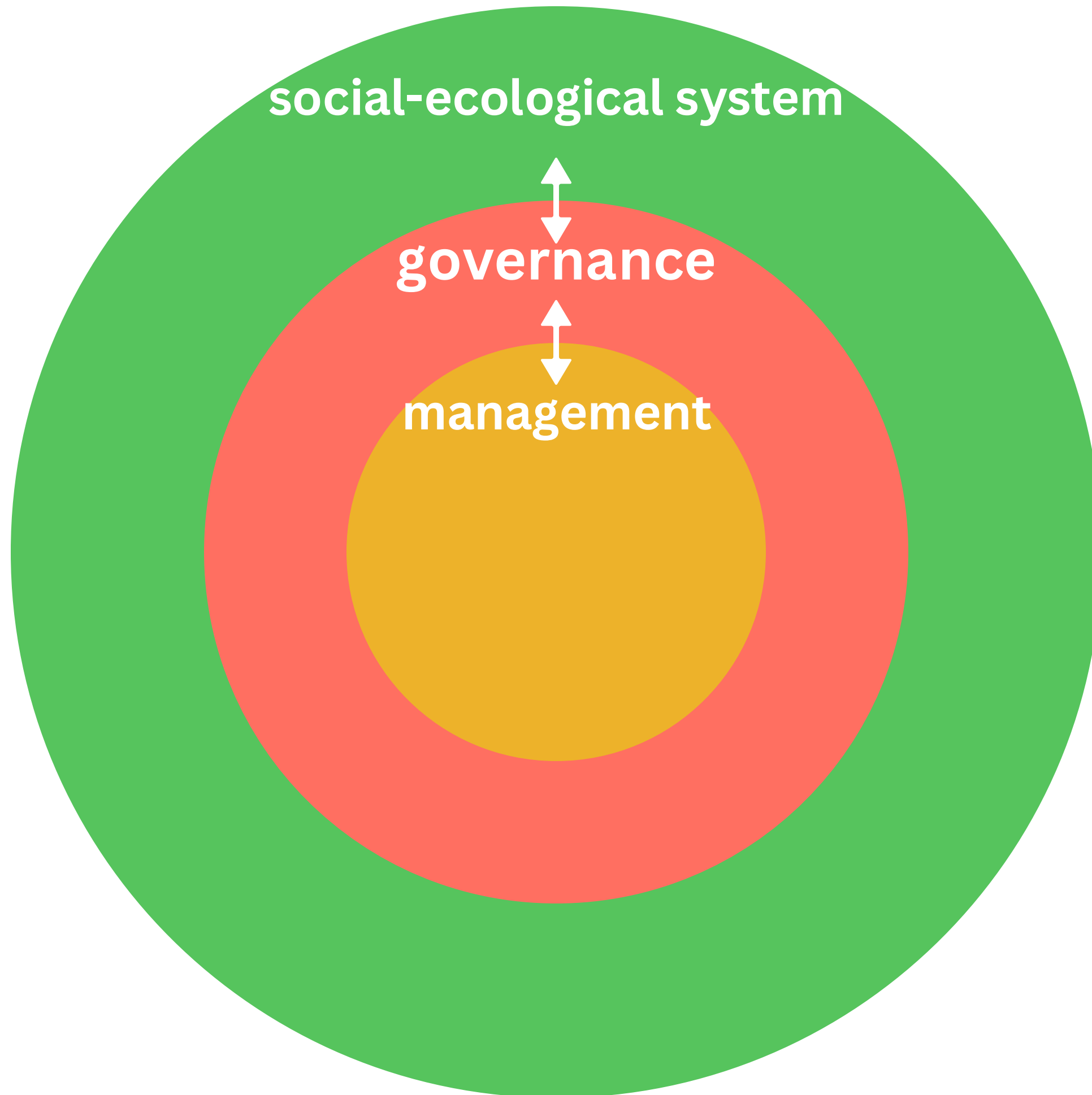

A FEW DISTINCTIONS

- Difference between government and governance
- water management (includes monitoring)

THE EVOLUTION OF THE MODERN DAM CONFLICT ON THE SNAKE RIVER, USA

THE EVOLUTION OF THE MODERN DAM CONFLICT ON THE SNAKE RIVER, USA



- ◆ Dam (not to scale)
- ① Ice Harbor (1962) ② Lower Monumental (1969)
③ Little Goose (1970) ④ Lower Granite (1975)

A Brief History of the Conflict

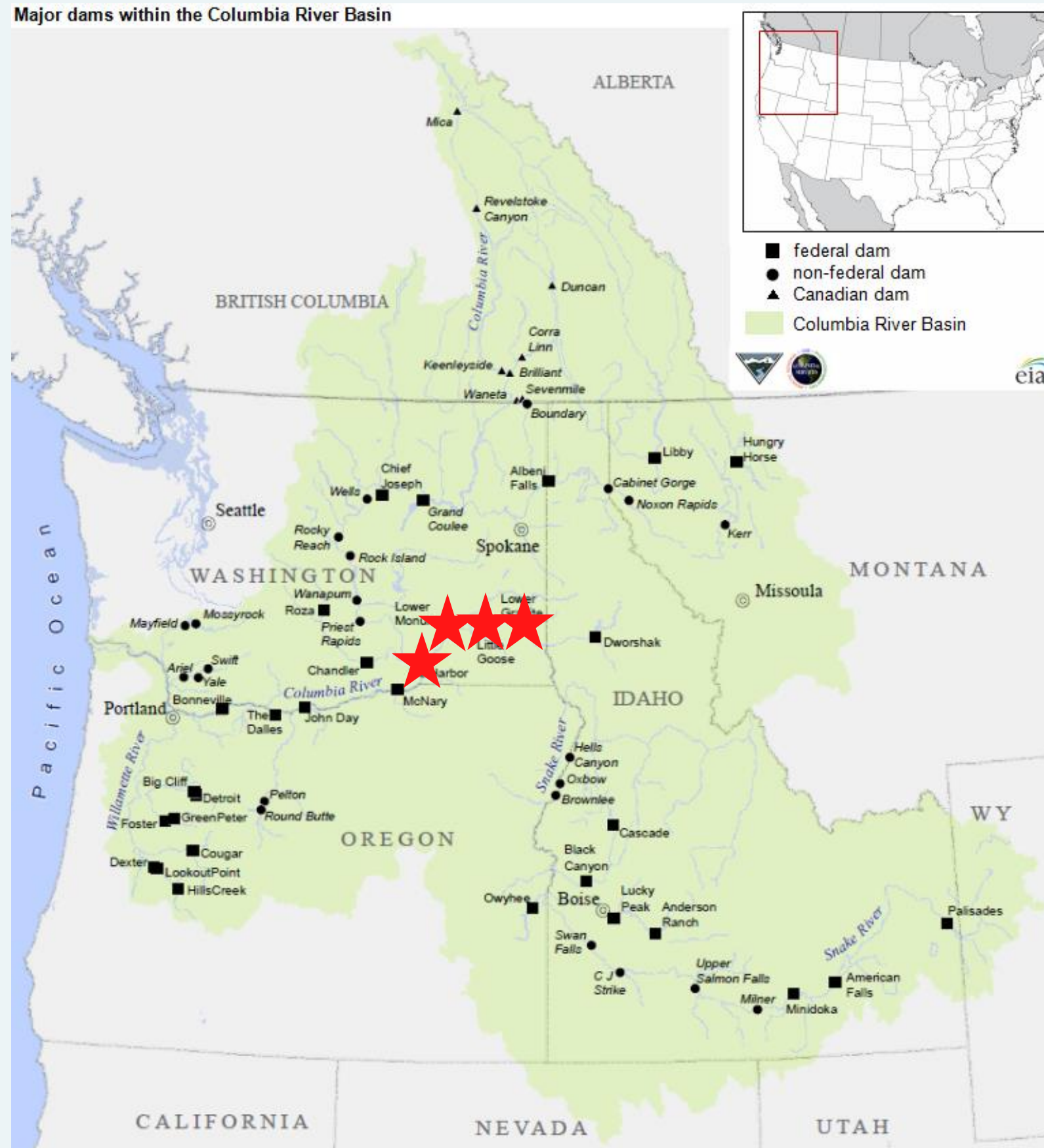

Since NOAA Fisheries began issuing BiOps in 1992 for the CRB salmon, every BiOp issued has been challenged in court.

Case studies

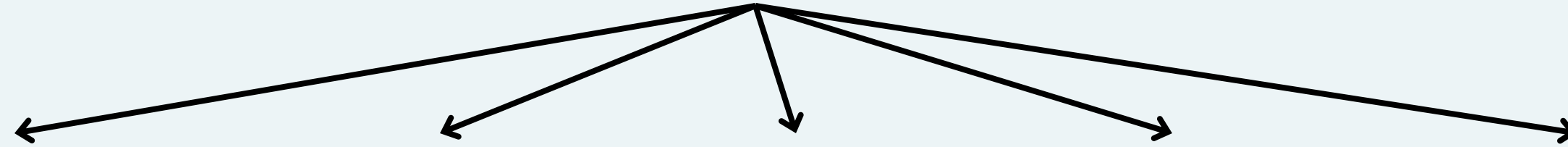

Key factors

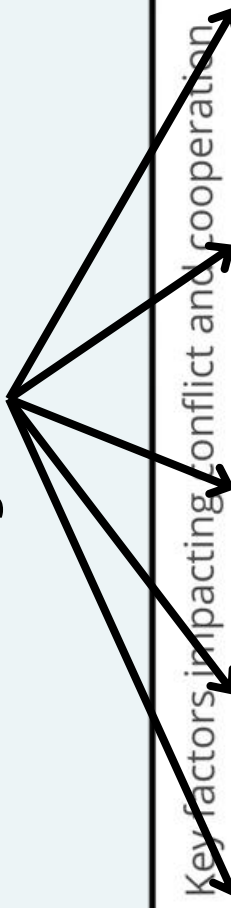

Case studies	CHAFFIN & GOSNELL (2017)	GABROWSKI ET AL. (2017)	MAGILLIGAN ET AL. (2017)	FOX ET AL. (2016)	GOSNELL & KELLY (2010)
Key factors impacting conflict and cooperation	Endangered species	Environmental dimensions	Institutional structure & dynamics	Competing interpretations of science & environment (environmental knowledges)	Innovative approach to negotiation: scaled forum for integrating multiple basin needs [venue]
	Presence of Native American tribes with fishing and water rights	Social dimensions (knowledge systems, cultural values and identities)	Framing of dam removal in economic, political, and cultural terms	Role of multiple actors	Growth of bottom-up, place-based approach to collaborative governance
	Venues (FERC relicensing process)	Technological dimensions	Historical & geographical contingencies	Micropolitics (insiders v outsiders)	NGOs holding governments accountable
	Economics	Financial dimensions	Place-based politics	Complex cultural dynamics: history, identity, aesthetics (landscape identities)	Unified, local leadership
	Local politics	Political dimensions			Robust legal framework
Key	 science	 stakeholder interactions	 economics	 political and cultural dynamics	

Environmental decisions are deeply embedded in socio-political and economic landscapes



**1
Politicization of
science and
economics**

Environmental decisions are deeply embedded in socio-political and economic landscapes

● 1

Politicization of science and economics

● 2

Persistent legal battles; expanded, but ineffective, stakeholder engagement

Environmental decisions are deeply embedded in socio-political and economic landscapes

● 1

Politicization of science and economics

● 2

Persistent legal battles; expanded, but ineffective, stakeholder engagement

● 3

A focus on values

What have we learned from studying dam removal conflicts?

- Conflicts are not typically about the physical structure, hydrology, or ecology (in fact, more physical science ≠ resolution, as science can be politicized)



What have we learned from studying dam removal conflicts?

- Conflicts are not typically about the physical structure, hydrology, or ecology (in fact, more physical science ≠ resolution, as science can be politicized)
- Conflict is often rooted in social values, historical situations, politics, power dynamics, and competing visions for place and identity, justice

What have we learned from studying dam removal conflicts?

- Conflicts are not typically about the physical structure, hydrology, or ecology (in fact, more physical science ≠ resolution, as science can be politicized)
- Conflict is often rooted in social values, historical situations, politics, power dynamics, and competing visions for place and identity, justice
- Trust and inclusive governance (equity, co-production of knowledge, long-term relationship building) often lead to conflict resolution

Reimagining hydropower in the United States

Hannah L. Haemmerli^{1,2}  | Andrea K. Gerlak³  | Tyler Swanson⁴ 



¹School of the Environment, Washington State University, Pullman, Washington, USA

²Udall Center for Studies in Public Policy, University of Arizona, Tucson, Arizona, USA

Abstract

In this *Perspective*, we review the clashing narratives around the role of hydropower in the United States' (US) energy future. In doing so, we reveal how hydropower is regarded as a keystone for the renewable energy transition but

Reimagining hydropower in the United States

Hannah L. Haemmerli^{1,2}  | Andrea K. Gerlak³  | Tyler Swanson⁴ 

¹School of the Environment, Washington State University, Pullman, Washington, USA

²Udall Center for Studies in Public Policy, University of Arizona, Tucson, Arizona, USA



Abstract

In this *Perspective*, we review the clashing narratives around the role of hydropower in the United States' (US) energy future. In doing so, we reveal how hydropower is regarded as a keystone for the renewable energy transition but

the world's largest renewable source of electricity (~50%)

“61% of the Earth's seasonal surface water storage variability occurs in human-managed reservoirs”
Cooley et al., 2021

Reimagining hydropower in the United States

Hannah L. Haemmerli^{1,2}  | Andrea K. Gerlak³  | Tyler Swanson⁴ 

¹School of the Environment, Washington State University, Pullman, Washington, USA

²Udall Center for Studies in Public Policy, University of Arizona, Tucson, Arizona, USA

Abstract

In this *Perspective*, we review the clashing narratives around the role of hydropower in the United States' (US) energy future. In doing so, we reveal how hydropower is regarded as a keystone for the renewable energy transition but

the world's largest renewable source of electricity (~50%)

“61% of the Earth's seasonal surface water storage variability occurs in human-managed reservoirs”
Cooley et al., 2021

Technology enmeshed in environmental degradation, social conflict, and economic hardship

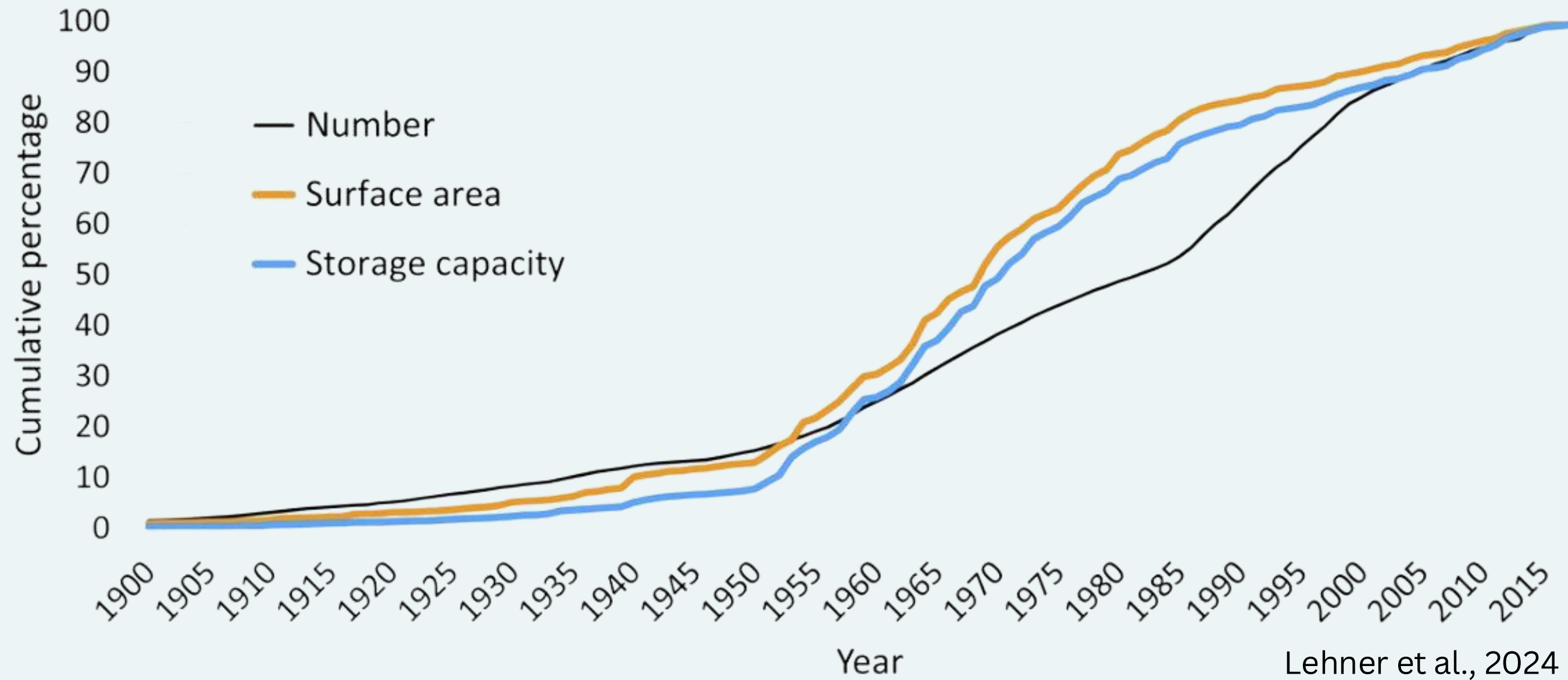

Hydropower has been central to U.S. industrialization since the 19th century. Peak construction of large dams occurred in the mid-20th century, followed by a **decline due to rising awareness of environmental impacts.**

Renewed interest in the US

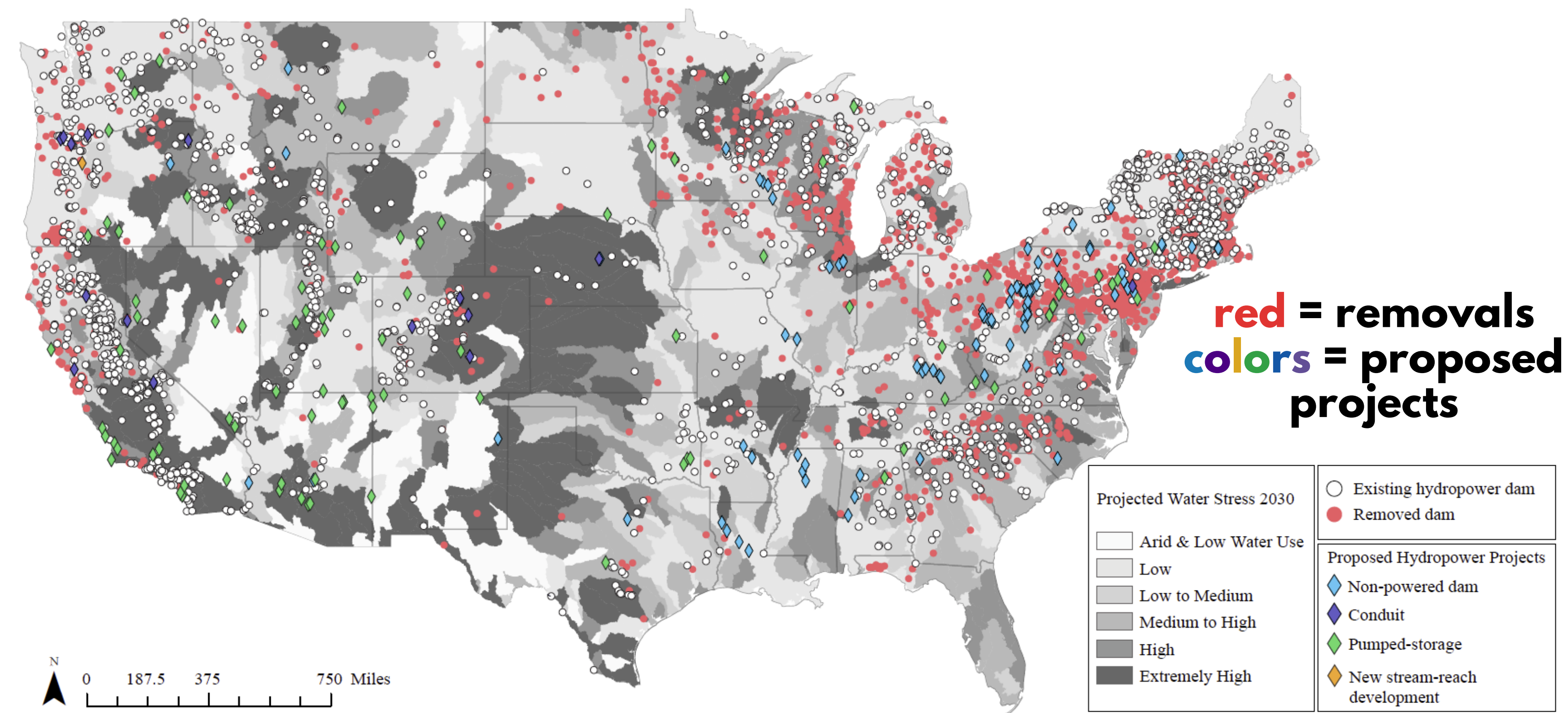

Limits to Technologic Solutions

Technologies

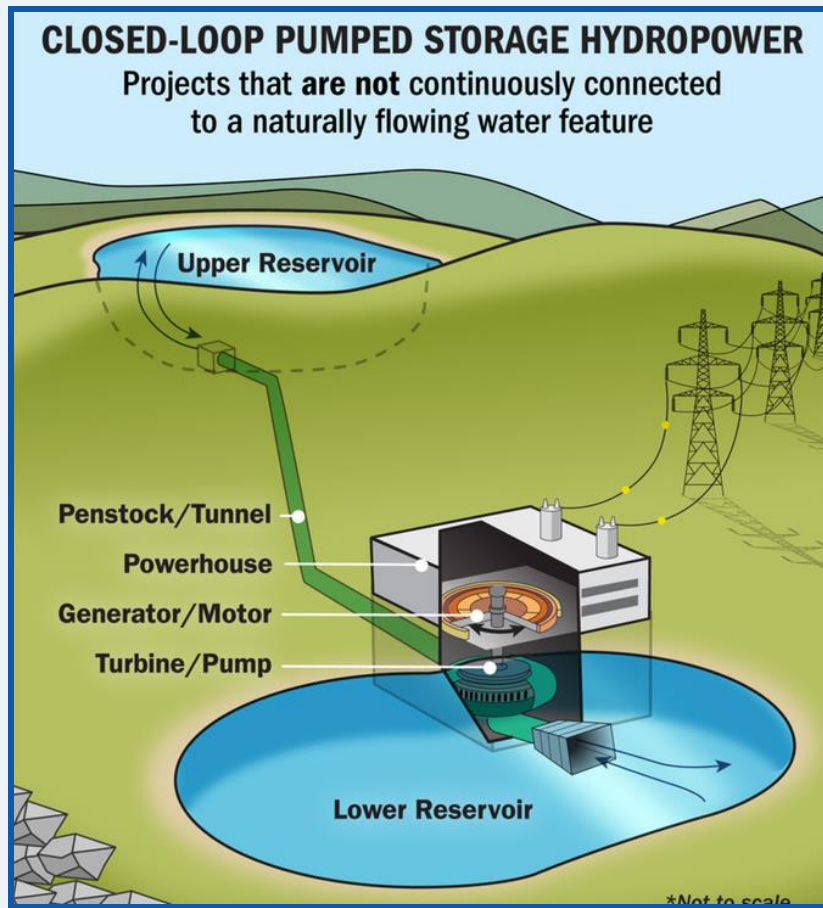

Dept. of Energy



ORNL



Turbulen

Technologie

Limits to Technologic Solutions

Familiar Conflicts

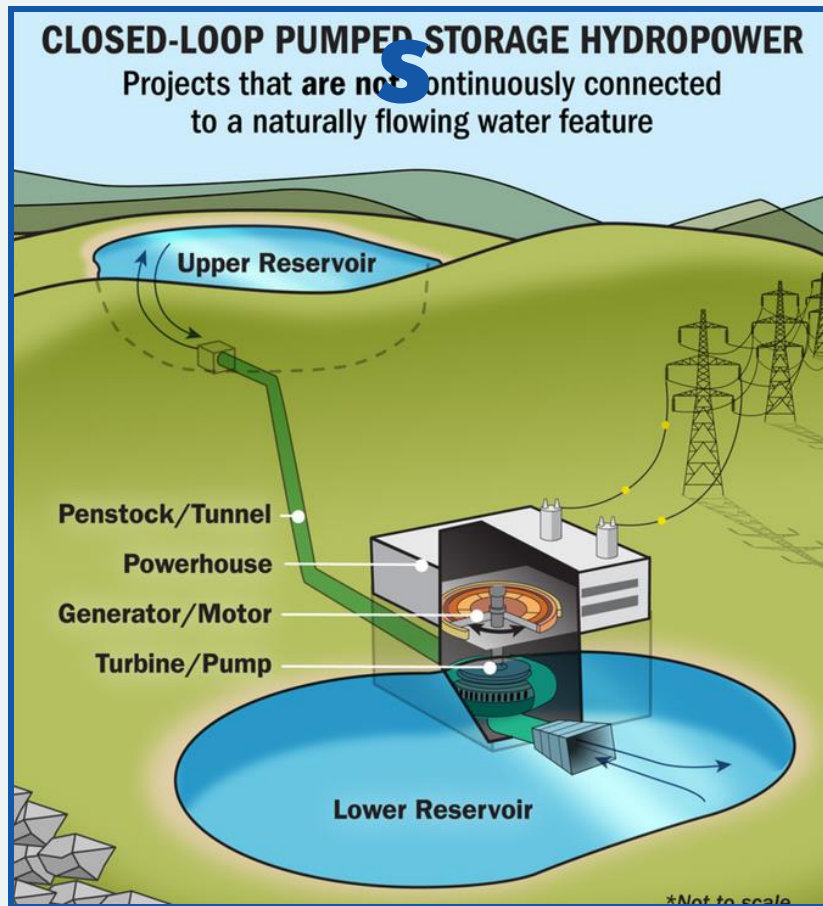

Dept. of Energy



Turbulen



ORNL

FEATURED

Tribes oppose Goldendale pumped storage project on Indigenous gathering grounds

By Flora Gibson Columbia Gorge News Sep 18, 2024

A Fight Over America's Energy Future Erupts on the Canadian Border

Power companies, conservationists, local residents and two U.S. states are mired in an acrimonious dispute about hydroelectricity from Quebec.

Oklahoma reps to hold study on controversial proposed pumped storage project

October 24, 2024 Sean Wolfe

3 MIN READ SHARE TO:

Southern frontlines: Latin America and the Caribbean

This article is more than 1 year old

'He had a machete in his cheek': how Guatemala's hydropower dream turned deadly

Latin America's water wars: The people of the Ixquisis valley thought their most valuable resource would help lift their villages out of



**THINGS MAY
LOOK
DIFFERENT,**

Example:

- **Pumped Storage Projects**
 - New projects like the Goldendale Energy Storage Project in WA face opposition for cultural and ecological impacts on Tribal lands and local ecosystems.

**BUT FAMILIAR
TENSIONS
REMAIN...**

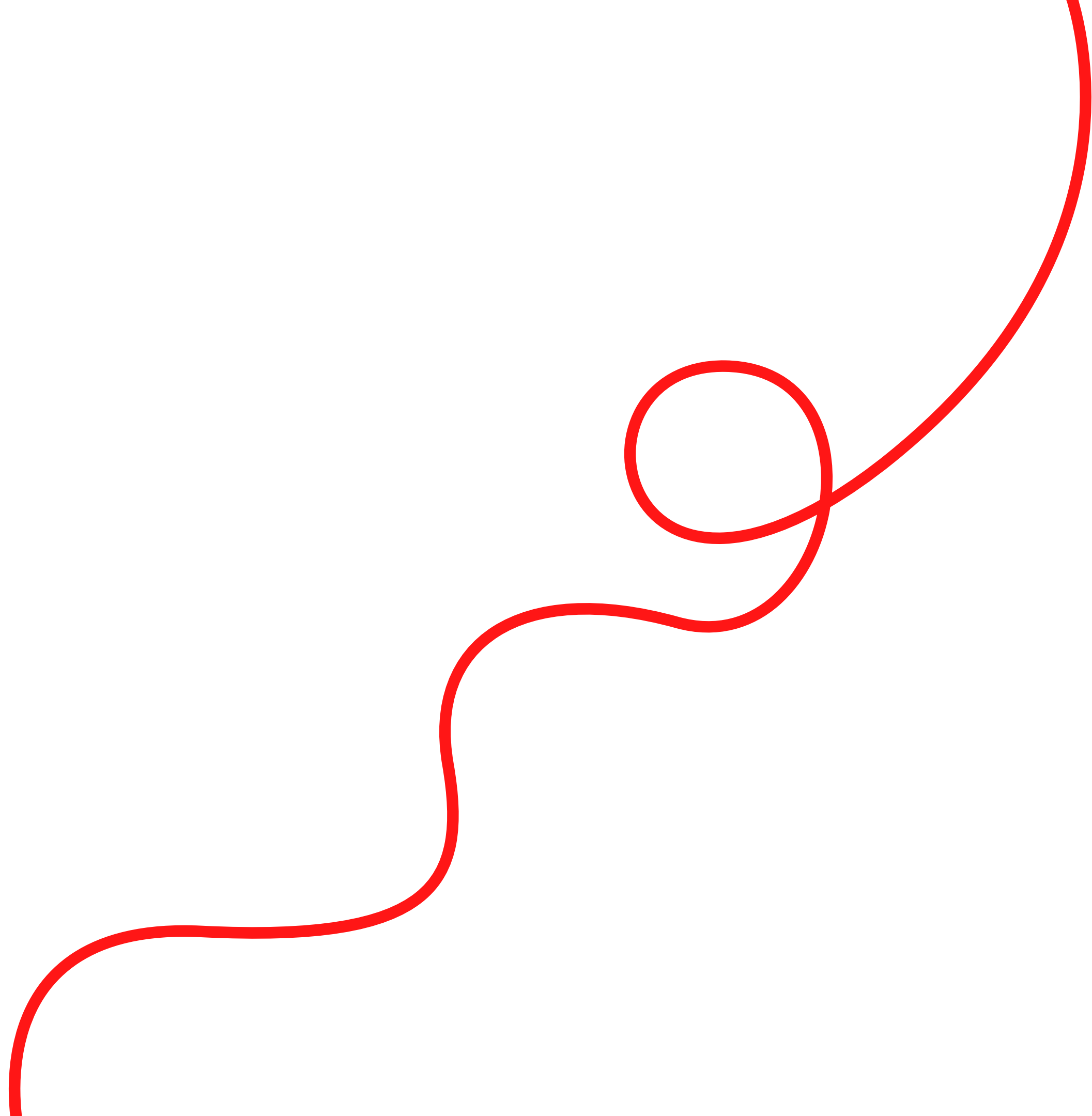

Water as blue thread





**Health &
Well-
being**

Energy

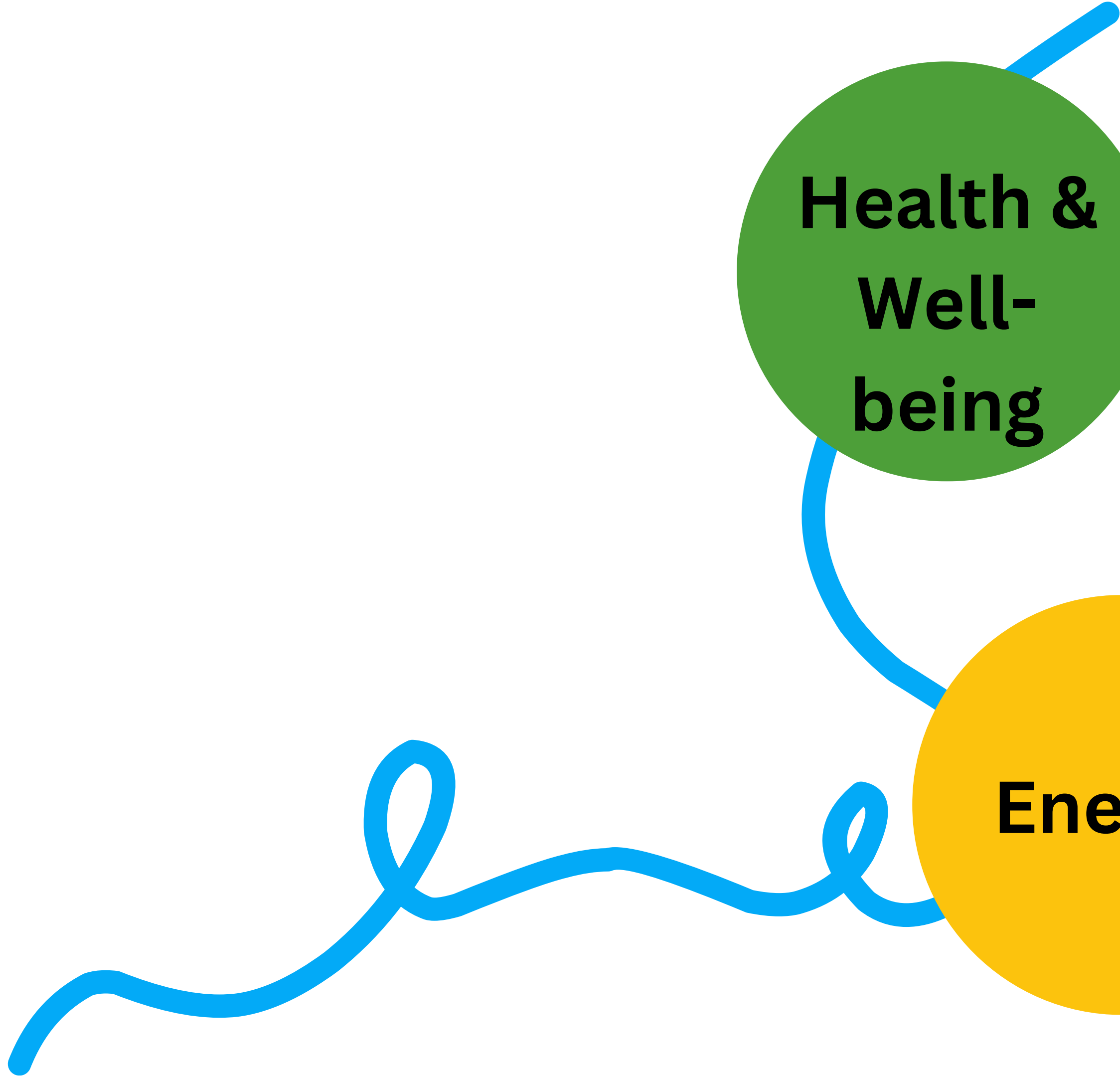



Peace

**Health &
Well-
being**

Energy

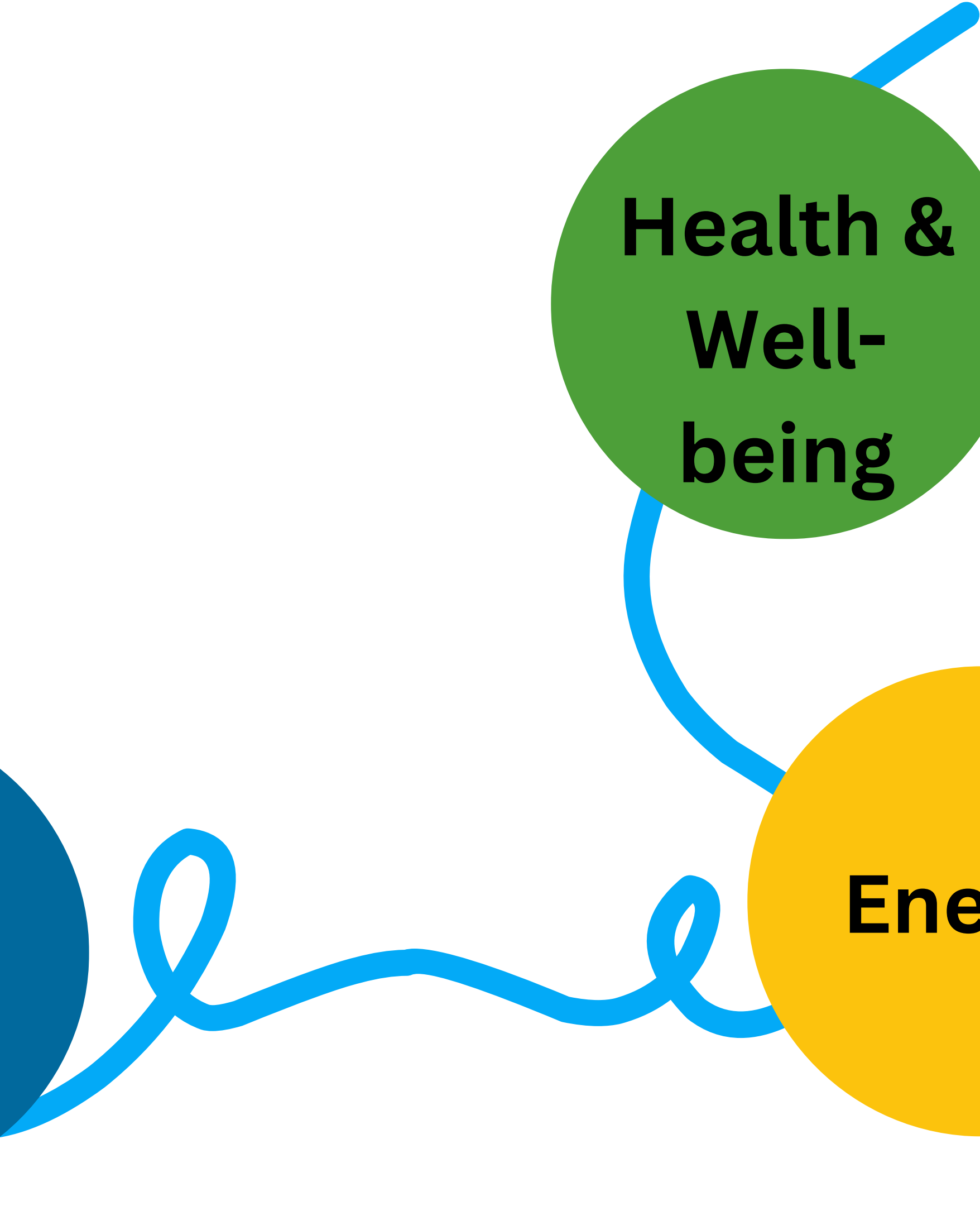

Water as a source of peace

Blue Peace refers to water cooperation across borders, sectors and generations to foster peace, stability and sustainable development.

<https://www.thebluepeaceinitiative.org/about-blue-peace-who-we-are.html>

**water can be a catalyst for cooperation
and peacebuilding among nations and
communities**

What does the research say?

Cooperation over water is much more common than conflict over water

Pioneering work of Aaron Wolf (OSU) demonstrated that there are many more instances of states cooperating over shared water resources rather than fighting over them.

Adversarial states can cooperate over water



image:
historyhaven.com

see: Wolf,

1.the Palouse we have

1



- 1.the Palouse we have
2. the Palouse we want

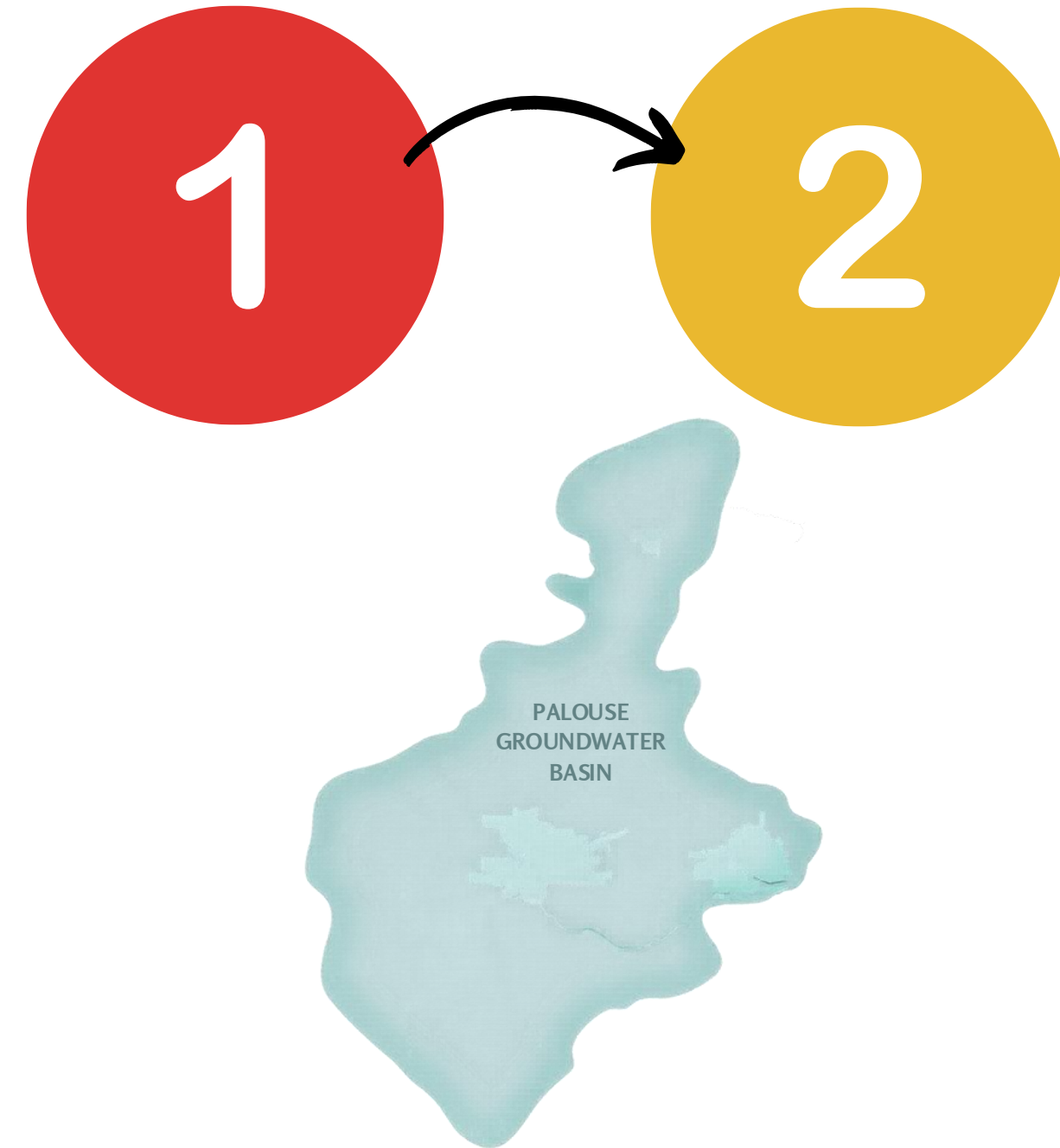

- 1.the Palouse we have
- 2.the Palouse we want
- 3.we cannot have the Palouse we want, without the water we need



- 1.the Palouse we have
- 2.the Palouse we want
- 3.we cannot have the Palouse we want, without the water we need
- 4.we cannot have the water we need, without the climate we need



- 1.the Palouse we have
- 2.the Palouse we want
- 3.we cannot have the Palouse we want, without the water we need
- 4.we cannot have the water we need, without the climate we need
- 5.we cannot have the water or climate we need without the **policies or institutions** (or, **governance**) we need



- 1.the Palouse we have
- 2.the Palouse we want
- 3.we cannot have the Palouse we want, without the water we need
- 4.we cannot have the water we need, without the climate we need
- 5.we cannot have the water or climate we need without the policies or institutions (or, governance) we need
- 6.without these, we are back to the world we had...

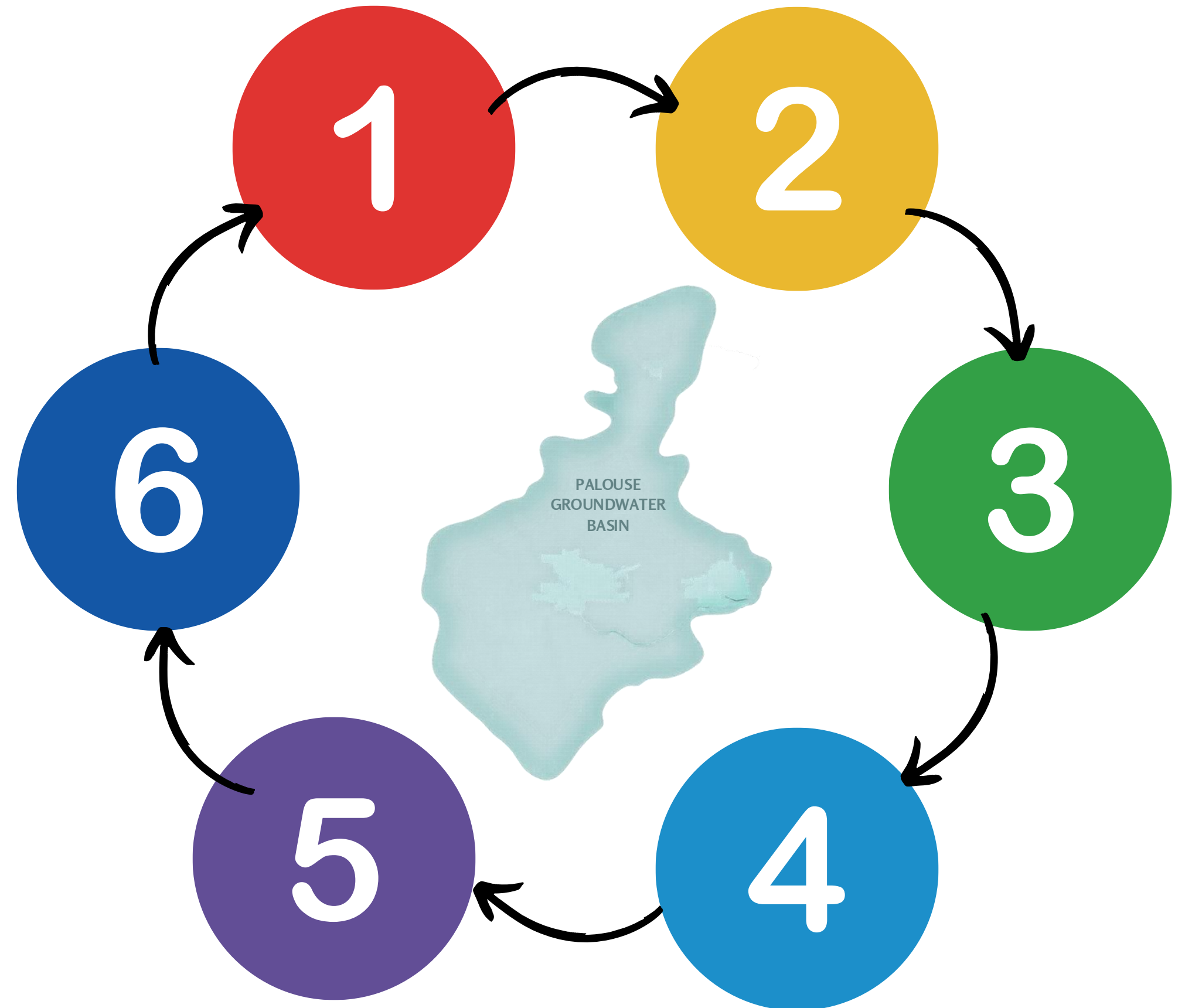

- 1.the Palouse we have
- 2.the Palouse we want
- 3.we cannot have the Palouse we want, without the water we need
- 4.we cannot have the water we need, without the climate we need
- 5.we cannot have the water or climate we need without the policies or institutions (or, governance) we need
- 6.without these, we are back to the world we had...



Summary of Take-aways

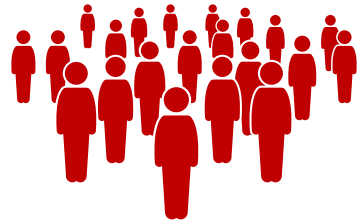

- Water challenges are rarely just technical challenges



Summary of Take-aways



- Water challenges are rarely just technical challenges



- Water systems are co-produced by nature and society: As water consumption and demand are increasing in the light of climate change and population growth, further insights from social science work are vital



Summary of Take-aways



- Water challenges are rarely just technical challenges



- Water systems are co-produced by nature and society: As water consumption and demand are increasing in the light of climate change and population growth, further insights from social science work are vital



- Institutions and power determine outcomes: consider the governance “side” of your challenge: conflict often arises not from scarcity but from governance failures

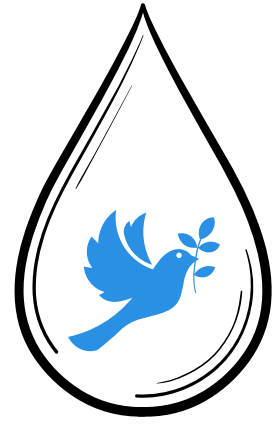

The Importance of Governance in Practice

- Complex environmental challenges are often about who decides and how decisions are made
- Where conflict emerges, it often reflects failures in governance processes & institutions, rather than the technical idea itself
- Solutions can stall when key stakeholders are not meaningfully included, when institutions aren't adaptable, strong
- The key is to design governance processes that make solutions possible from the outset

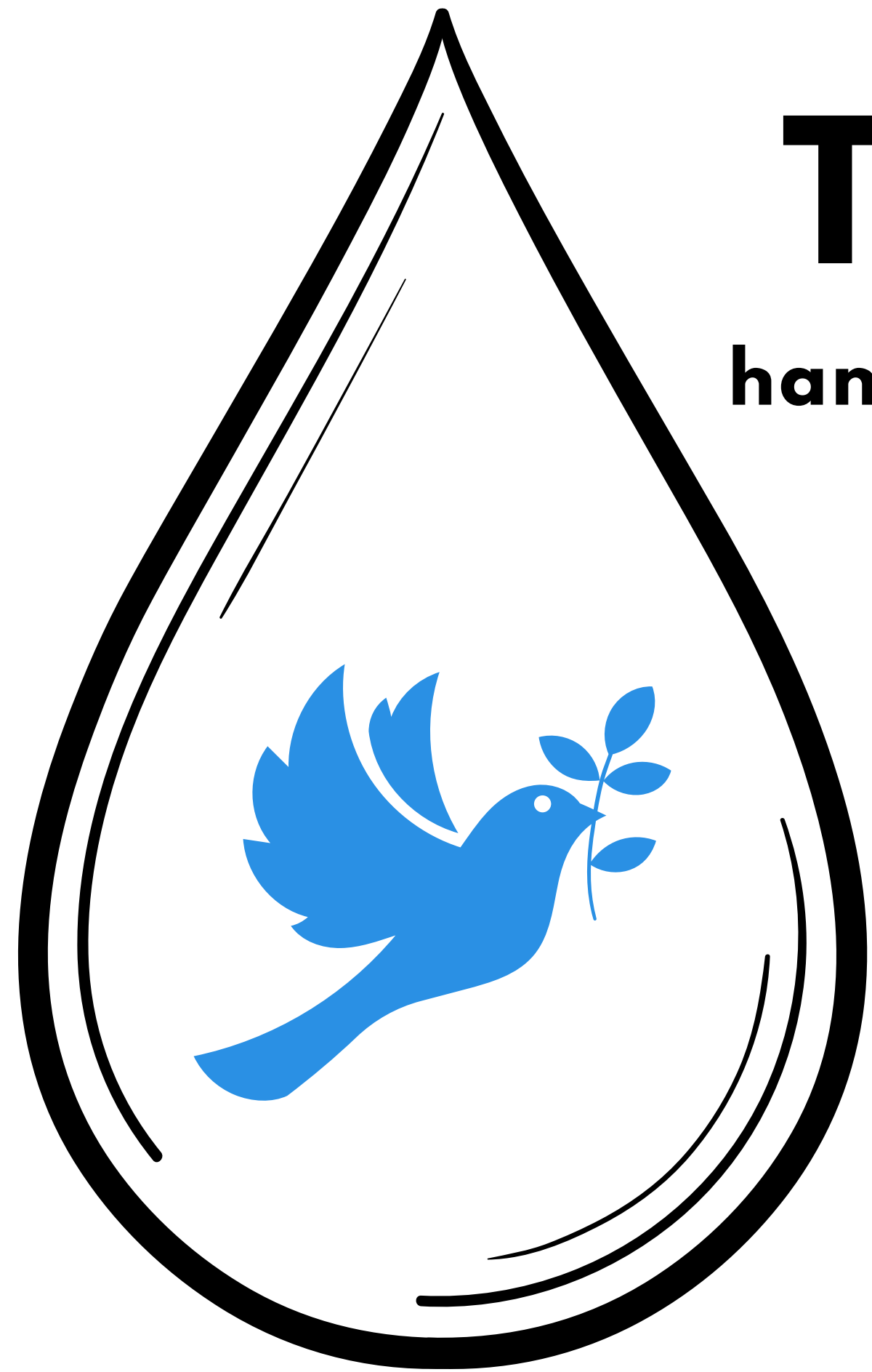

Thank you!
hannah.haemmerli@wsu.edu
u

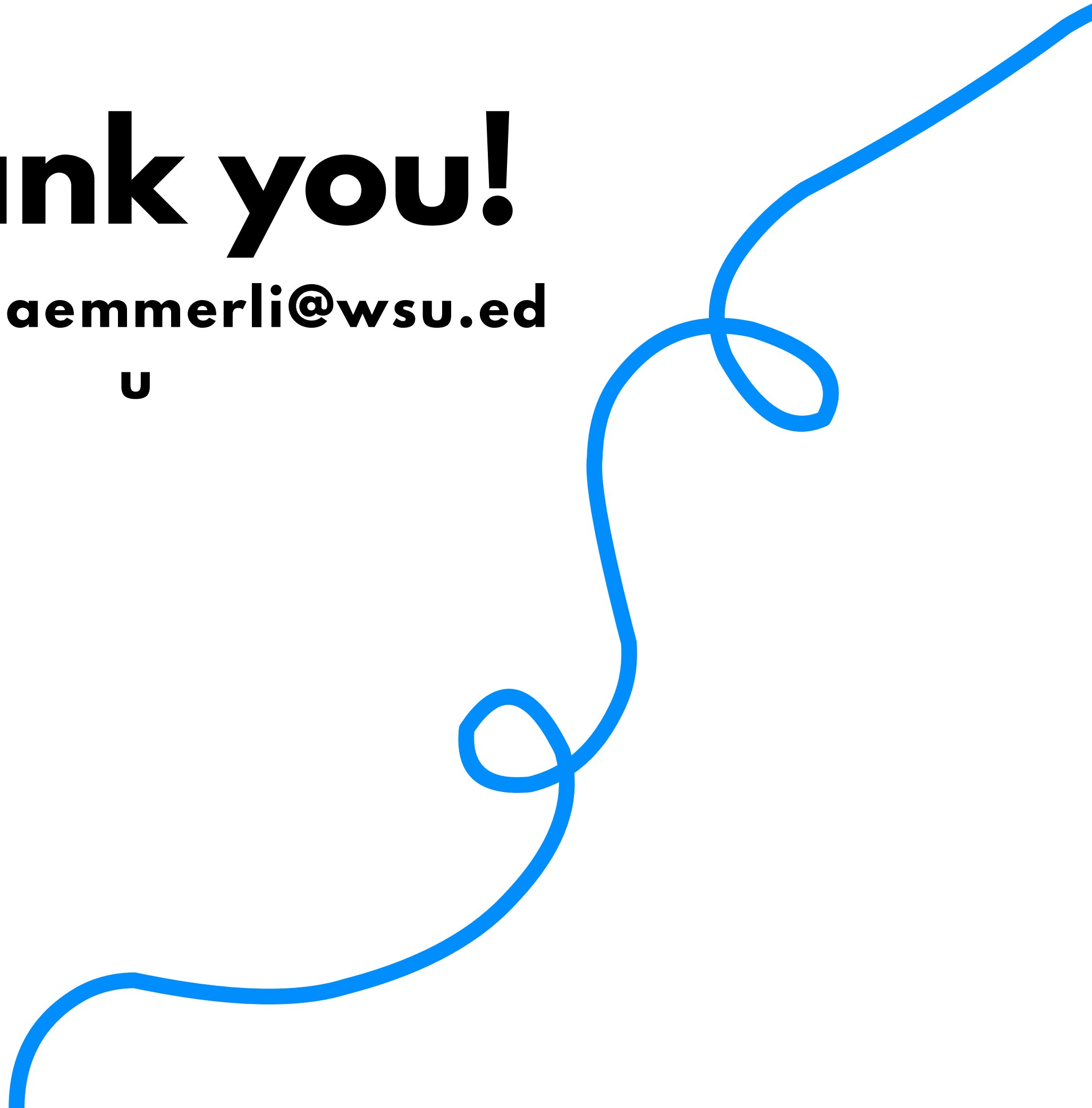

What we can do (with the research) in practice:

See for example: Delli Priscoli & Wolf, 2009; Zeitoun et al., 2020; Giordano & Wolf, 2003; De Stefano et al., 2017; Zeitoun & Mirumachi, 2008; Pahl-Wostl, 2015; Ostrom et al. (2003)

What we can do (with the research) in practice:

Institutions matter - increase institutional capacity - absorb shocks; prevent escalation

See for example: Delli Priscoli & Wolf, 2009; Zeitoun et al., 2020; Giordano & Wolf, 2003; De Stefano et al., 2017; Zeitoun & Mirumachi, 2008; Pahl-Wostl, 2015; Ostrom et al. (2003)

What we can do (with the research) in practice:

Institutions matter - increase institutional capacity - absorb shocks; prevent escalation

Polycentric
governance

See for example: Delli Priscoli & Wolf, 2009; Zeitoun et al., 2020; Giordano & Wolf, 2003; De Stefano et al., 2017; Zeitoun & Mirumachi, 2008; Pahl-Wostl, 2015; Ostrom et al. (2003)

What we can do (with the research) in practice:

Institutions matter - increase institutional capacity - absorb shocks; prevent escalation

Polycentric governance

Capacity to learn

See for example: Delli Priscoli & Wolf, 2009; Zeitoun et al., 2020; Giordano & Wolf, 2003; De Stefano et al., 2017; Zeitoun & Mirumachi, 2008; Pahl-Wostl, 2015; Ostrom et al. (2003)

What we can do (with the research) in practice:

Institutions matter - increase institutional capacity - absorb shocks; prevent escalation

Polycentric governance

Capacity to learn

scales: e.g., community-based water governance can strengthen trust, reduce social tensions

See for example: Delli Priscoli & Wolf, 2009; Zeitoun et al., 2020; Giordano & Wolf, 2003; De Stefano et al., 2017; Zeitoun & Mirumachi, 2008; Pahl-Wostl, 2015; Ostrom et al. (2003)

What we can do (with the research) in practice:

Institutions matter - increase institutional capacity - absorb shocks; prevent escalation

Incorporate governance solutions into problem solving

Capacity to learn

Recognize that water interactions are inherently political

See for example: Delli Priscoli & Wolf, 2009; Zeitoun et al., 2020; Giordano & Wolf, 2003; De Stefano et al., 2017; Zeitoun & Mirumachi, 2008; Pahl-Wostl, 2015; Ostrom et al. (2003)

GOVERNANCE AND COLLABORATIVE SOLUTIONS

- **Innovative Governance:** Collaborative governance can bridge diverse interests, increase transparency, and include marginalized voices in hydropower decision-making.
 - Example: The Penobscot River restoration in Maine successfully balanced hydropower with ecological restoration and Tribal involvement by taking a basin-scale approach.
- **System-Scale Planning:** Future projects can benefit from holistic planning across entire river basins, considering both energy needs and ecological impacts.
- **Equity and Justice:** In the renewable energy transition, it is crucial to recognize that energy cannot be considered in isolation from the complex systems within which it operates.

What does the research say?

- Shared water fosters dialogue
- Institutions matter - lead to durable peace
- Prevents escalation - cooperation ≠ absence of conflict
- At smaller scales, community-based water governance can strengthen trust and reduce social tensions

What are the challenges?

Water problems are not just technical or hydrological

“Water governance has emerged as one of the most critical areas in the context of sustainable water resources development and services, necessary to respond to global water shortages – a crisis which is not about having too little water to satisfy our needs, but rather a crisis of managing water and making it accessible to all.”

-UNDP, 2015

What are the challenges?

Water problems are not just technical or hydrological

“Water governance has emerged as one of the most critical areas in the context of sustainable water resources development and services, necessary to respond to global water shortages – a crisis which is not about having too little water to satisfy our needs, but rather a crisis of managing water and making it accessible to all.”

-UNDP, 2015

**They are social, political,
and institutional**